

# AC.NLCC.V01 NAVIGATION LIGHT CONTROL CARD USER MANUAL

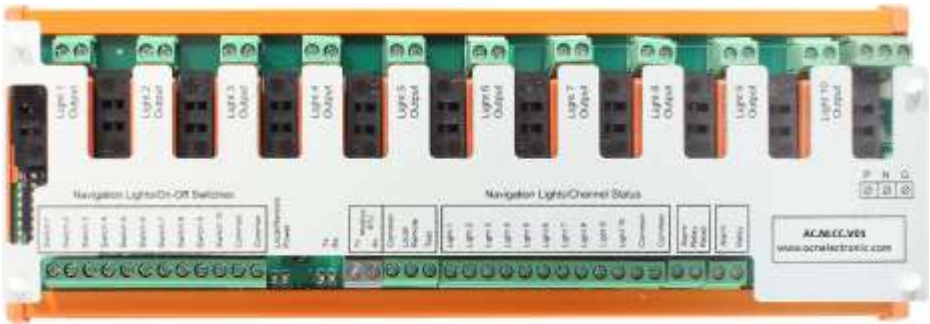

# CONTENTS

<b>GENERAL FEATURES .....</b>	<b>2</b>
<b>SETUP.....</b>	<b>3</b>
<b>CONTROL WITH MIMIC PANEL: .....</b>	<b>3</b>
<b>CONTROL WITH NLCP:.....</b>	<b>5</b>
<b>CONTROL WITH PLC or OTHER INDUSTRIAL DEVICES:.....</b>	<b>7</b>
<b>MODBUS RTU REGISTER TABLES.....</b>	<b>12</b>
<b>TROUBLESHOOTING .....</b>	<b>14</b>
<b>DIMENSIONS.....</b>	<b>16</b>

## GENERAL FEATURES

- Ability to operate in the range of 90-250 V AC 50-60 Hz.
- 10 led or filament navigation lights can be controlled **Manually, NLCP, PLC** or other industrial devices.(Via **Modbus RTU** communication)
- Ability to switch 65W each channel.
- Shows the open and short circuit status of each channel.
- Fuse protection is available at the exit of each channel.
- The status of each navigation light can be displayed by led.
- The alarm output is activated when a short circuit or open circuit occurs in one or more of the navigation light outputs.
- The alarm relay output is 5 A.

## SETUP

**Attention:** When connecting any communication cable to the device or changing the DIP Switch position, make sure that the power is disconnected.

### CONTROL WITH MIMIC PANEL:

- Connect the "P", "N", "G" power cables of the **AC.NLCC.V01**.
- Connect the navigation lights to the corresponding navigation light outputs. (Navigation lights can be led or flemish lamps.)
- Unconnected channels of the navigation light outputs will not supply voltage for safety reasons.
- Switch all pins of the DIP Switch to the "OFF" position.
- Decouple the **JUMPER** connection between **Local/Remote - Common**.
- Connect the navigation light indicator LEDs to the corresponding led outputs in the **Channel Status** section. (The voltage of the **Channel Status** outputs is DC 12-24 V and the **Common** ends are (+) and the **Light** ends are (-).)

- **Alarm Relay** connection; Connect one end of the buzzer to the external voltage input and make the output of the external voltage to be connected to one end of the **Alarm Relay**, the other end of the buzzer to be connected to the other end of the **Alarm Relay**.
  
- **Alarm Relay Reset** connection; One end of the spring-loaded button is connected to one of the **Alarm Relay Reset** outputs, and the other end of the button is connected to the other of the **Alarm Relay Reset** outputs.
  
- **Test** connection; Make one end of the spring button to be connected to the **Common** end and the other end of the button to be connected to the Test end.
  
- **On-Off Switches** connection; Connect one end of the permanent switch to the corresponding **On-Off Switch** end and the other end to one of the Common ends.

Note: The connection method of the installation is shown in Picture-1,Picture-2 and in the sample connection diagrams.

## CONTROL WITH NLCP:

- Connect the "P", "N", "G" power cables of the **AC.NLCC.V01**.
- Connect **NLCP's Main** and **Emg** power cables.
- Connect the navigation lights to the corresponding navigation light outputs. (Navigation lights can be led or flemish lamps.)
- Unconnected channels of the navigation light outputs will not supply voltage for safety reasons.
- Connect the **Tx** end of **NLCP** to the **Tx** end of **AC.NLCC V01** and the **Rx** end of **NLCP** to the **Rx** end of **AC.NLCC V01**. (Cable length; maximum 30 mt)
- Activate the connection (**JUMPER**) between **Common** and **Local/Remote** terminals of **AC.NLCC.V01**.

- Set the **DIP Switch** on the **AC.NLCC.V01** to the “**ON**” position of pin 1.

***!!!! Make sure the power is off before changing the Dip Switch Position.***

- Connect the navigation light terminal outputs.
- Connect the alarm voltage input of the **NLCP** to the **C** end in the **Relay Output** section, connect the alarm voltage output of the **NLCP** to the **NO** end if you want it to work when the alarm is active, connect it to the **NC** end if you want it to work when the alarm is passive.

Note: The connection method of the installation is shown in Picture-3 and in the sample connection diagrams.

## CONTROL WITH PLC or OTHER INDUSTRIAL DEVICES:

- Connect the "P", "N", "G" power cables of the **AC.NLCC.V01**.
- Connect the navigation lights to the corresponding navigation light outputs. (Navigation lights can be led or filament lamps.)
- Unconnected channels of the navigation light outputs will not supply voltage for safety reasons.
- Connect the **Tx** end of the **PLC/Industrial Device** to the **Tx** end of the **AC.NLCC.V01** and the **Rx** end of the **PLC/Industrial Device** to the **Rx** end of the **AC.NLCC.V01**. (Cable length; maximum 30 mt)
- Activate the connection (JUMPER) between **Common** and **Local/Remote** terminals of **AC.NLCC.V01**.
- Set the **DIP Switch** on the **AC.NLCC.V01** to the **ON** position of pin 1.

***!!!! Make sure the power is off before changing the Dip Switch Position.***

- Connect the navigation light terminal outputs.

**Note:** The connection method of the installation is shown in Picture-4 and in the sample connection diagrams.



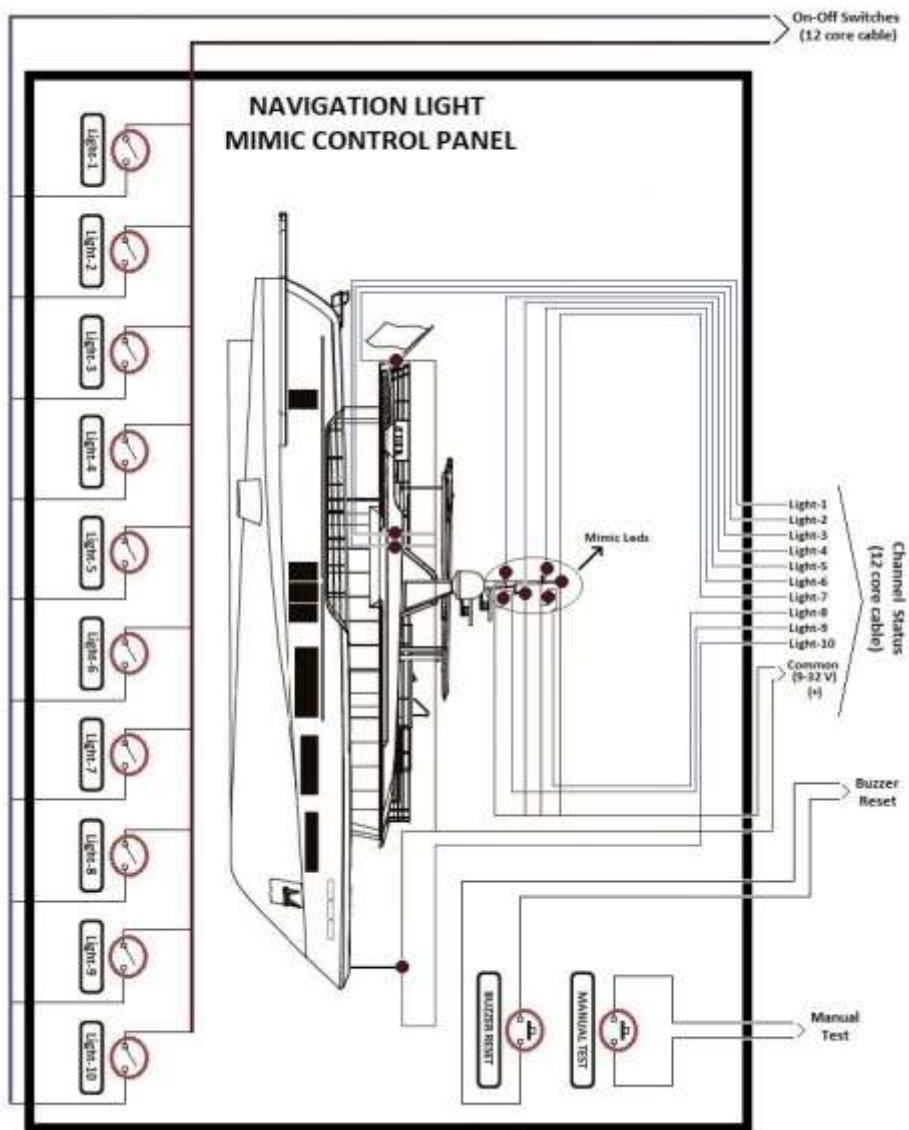

Picture\_1 : Mimic Panel Example Connection – 1

# SEYİR FENERLERİ/NAVIGATION LIGHTS

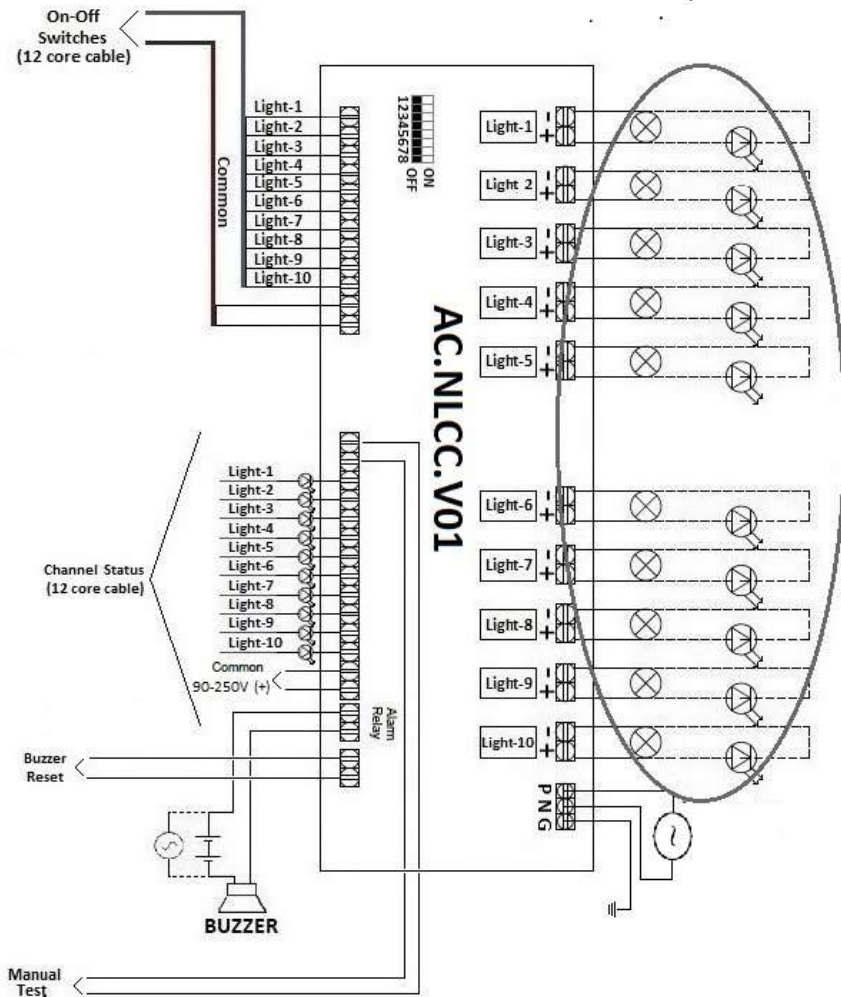

Picture\_2: Mimic Panel Example Connection – 2

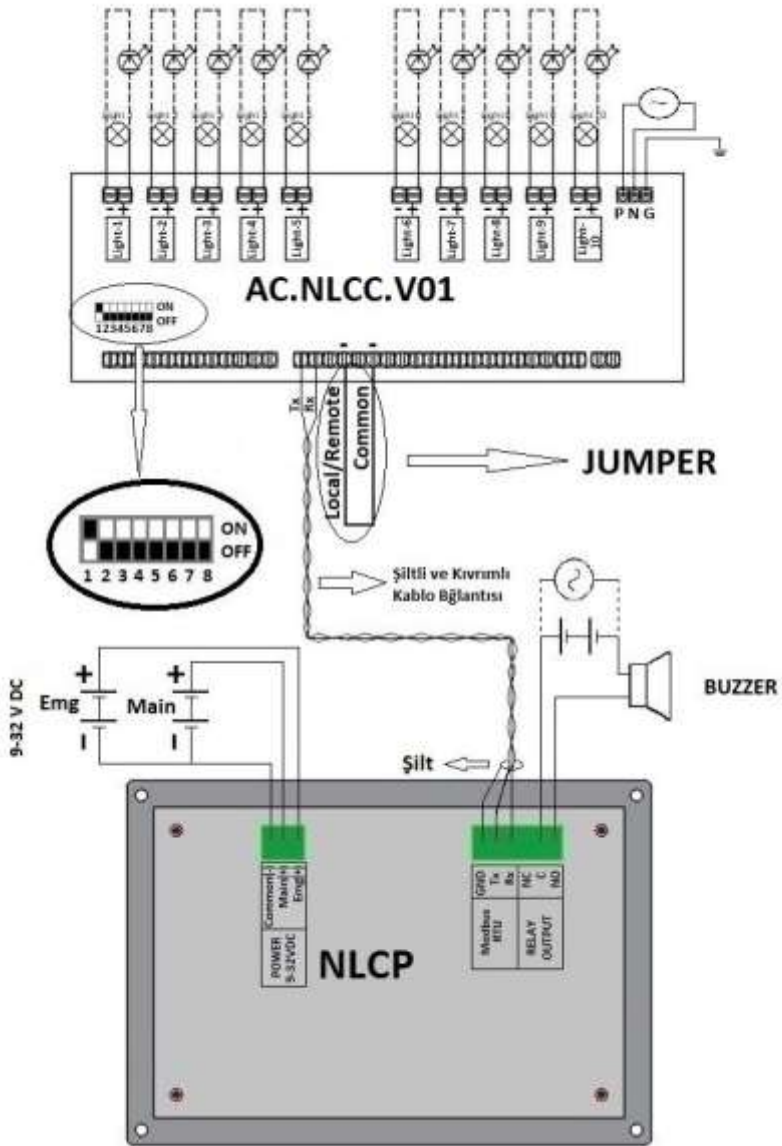

Picture\_3: NLCP Connection - 1

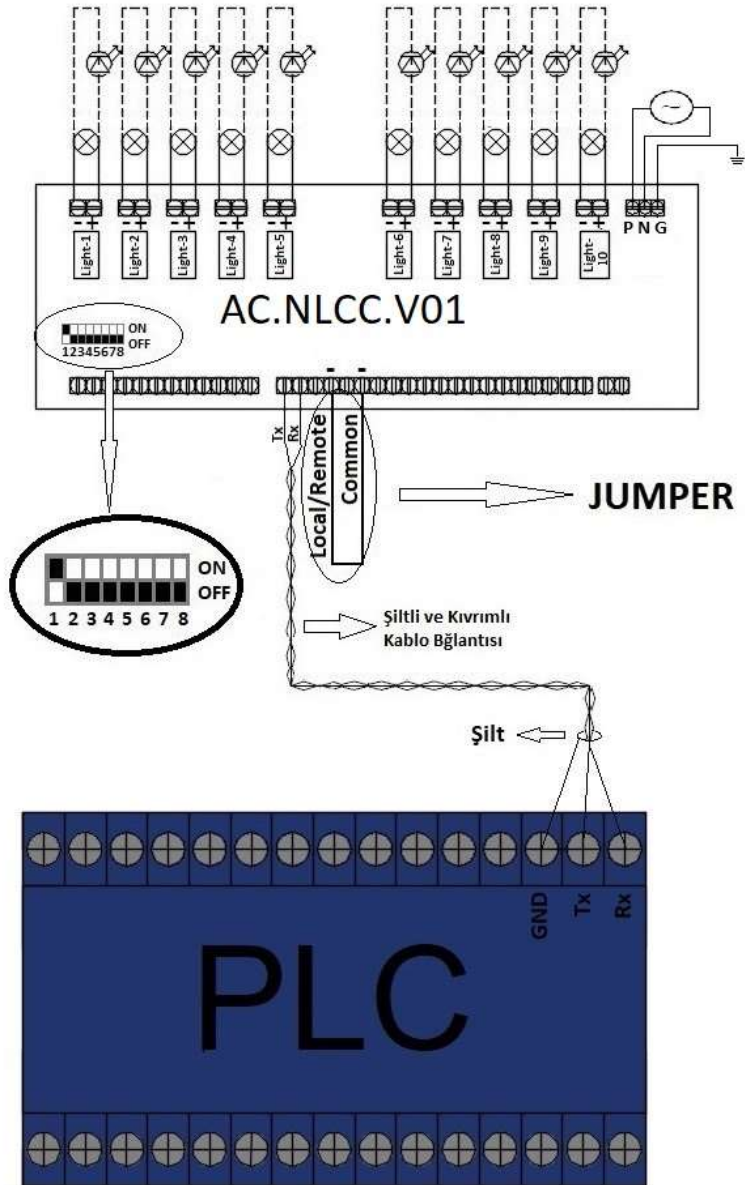

Picture\_4: PLC Connection – 1

## MODBUS RTU REGISTER TABLES

**Table-1:**

Register Address	Register Name	Register Type	Task
41	Control of Lamps	Integer	Writing
42	1. Lamp Status	Integer	Reading
43	2.Lamp Status	Integer	Reading
44	3.Lamp Status	Integer	Reading
45	4.Lamp Status	Integer	Reading
46	5.Lamp Status	Integer	Reading
47	6.Lamp Status	Integer	Reading
48	7.Lamp Status	Integer	Reading
49	8.Lamp Status	Integer	Reading
50	9.Lamp Status	Integer	Reading
51	10.Lamp Status	Integer	Reading
52	Lamp-1 Counter	Integer	Reading
53	Lamp-2 Counter	Integer	Reading
54	Lamp-3 Counter	Integer	Reading
55	Lamp-4 Counter	Integer	Reading
56	Lamp-5 Counter	Integer	Reading
57	Lamp-6 Counter	Integer	Reading
58	Lamp-7 Counter	Integer	Reading
59	Lamp-8 Counter	Integer	Reading
60	Lamp-9 Counter	Integer	Reading
61	Lamp-10 Counter	Integer	Reading
62	Power Status	Integer	Reading
63	Local/Remote Status	Integer	Reading

**Tablo-2:**

Lamp Control Registers	Lamp Outputs
Lights_Control_bit_0	Light_1_Output_Relay
Lights_Control_bit_1	Light_2_Output_Relay
Lights_Control_bit_2	Light_3_Output_Relay
Lights_Control_bit_3	Light_4_Output_Relay
Lights_Control_bit_4	Light_5_Output_Relay
Lights_Control_bit_5	Light_6_Output_Relay
Lights_Control_bit_6	Light_7_Output_Relay
Lights_Control_bit_7	Light_8_Output_Relay
Lights_Control_bit_8	Light_9_Output_Relay
Lights_Control_bit_9	Light_10_Output_Relay

**Note:**

- 42, 43, 44, 45, 46, 47, 48, 49, 50, 51 any one or more of the numbered registers; If "0", the corresponding lamp is not lit, if "1", the corresponding lamp is lit, if "2", the corresponding lamp is defective.
- if register No. 62 is "0", the power supply is provided from Main, and "1" is provided from Emg.
- if the register number 63 is "0", the device is in the local position, and if "1", the device is in the remote position.

## TROUBLESHOOTING

### ***Power Led Error:***

- Check the power cable entries.

### ***Navigation Light(s) Error:***

- Check the navigation light terminal output connection.
- Check the On-Off Switch terminal connections.
- Check the navigation lights.

### ***Output Voltage Error:***

- Check the output fuse.
- Check the terminal cable connection and the strength of the cable line.
- Check the stability of the navigation light.
- For safety reasons, voltage will not be obtained from the outputs that are not connected to the navigation light.

### **Buzzer Error :**

- Check the Alarm Relay connection.
- Check the buzzer with the test button.

### **Communication error with PLC or Other Industrial Devices:**

- Check the terminal connections of the communication cables.
- If the communication LEDs are not synchronously lit, check that the Rx,Tx terminal blocks are connected correctly.
- Check the dip switch 1 is in the "ON" position.
- Check the Tx Rx connections of the Modbus RTU.
- Check NLCP V.00 is in Remote mode. (Jumper connection.)
- Check the NLCP or Modbus RTU connection of the Industrial Device.
- Check the power supply of the NLCP or Industrial Device.



## DIMENSIONS

**Top View :**

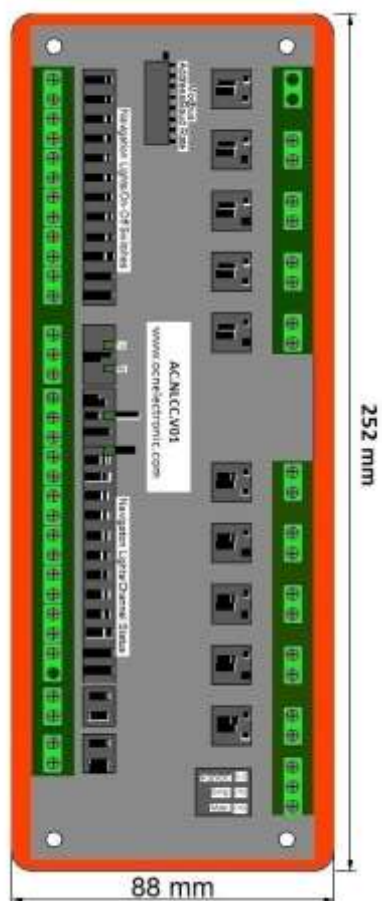

*Side view :*

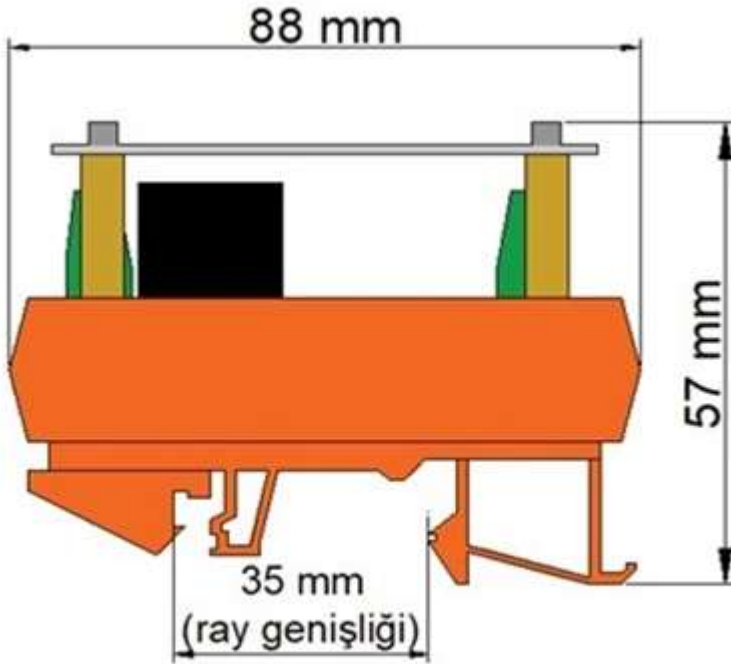

**Notes;**

## **OCN ELEKTRONİK VE TİCARET A.Ş.**

İçmeler Mahallesi Altunay Sokak

No:33 Kat:3 İç Kapı No:11

Tuzla/İSTANBUL

Telefon : +90 (216) 629 29 19

E-Posta : [info@ocnelectronic.com](mailto:info@ocnelectronic.com)

<http://ocnelectronic.com>

[www.ocnelectronic.com](http://www.ocnelectronic.com)